



BirdBike

USER MANUAL

BirdBike

A-Frame & V-Frame User Manual



Please read this manual very carefully before using the product. The manual contains important instructions for the safe use and longevity of your bike.

If you need any type of support or warranty information for your BirdBike, please contact us before returning it back to wherever you purchased it. The BirdBike Support Team is ready to help you via phone or email and you can also visit support.bird.co for more info.

Phone: 1-888-309-3702 (M-F 9a-5p EST)

Email: BirdBike@bird.co

Web: support.bird.co

BirdBike

A-FRAME



1 Assembly Prep

To prepare for the assembly of your BirdBike, first take out all pieces of the BirdBike from the box and remove all packaging. Also, open the accessory box and remove all tools, parts and everything else that's inside of it.



2.5 mm
Allen key



Pedals
(x 2)



3mm / 4mm /
5mm Y-wrench



L-key Phillips
Screwdriver



13mm / 15mm
Two-sided
Wrench



Cap nut and
washer



Wheel Reflectors
(x 2) and
fasteners (x 2)



Rear and Front
Reflectors



Battery Keys

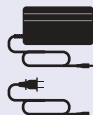

Power Supply
and Cable



This Manual

A-FRAME

Saddle

Tail light

Rear fender

Rear rim

Tire

Rear disc brake

Motor

Kickstand

Front sprocket

Crank

Pedal

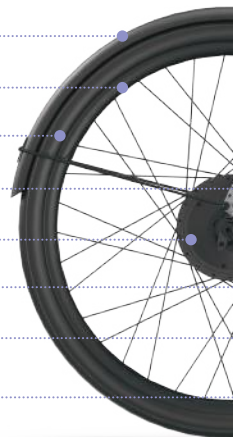



2 Install the handlebar

Remove Display from the Handlebar

Use the 2.5mm Allen Key to remove the screw that's behind the display on the handlebar. If the display isn't easily removed from the handlebar, use the hex key to gently push it from the back of the handlebar through the hole from where the screw was removed.

2.5 mm Allen key

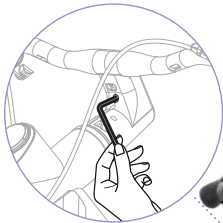

A-FRAME

Install the Handlebar

Use the 5mm end of the Y-wrench to remove the hex bolt from inside the steerer tube and insert the handlebar over the steerer tube.

After the handlebar is installed and lined up properly with the tire and frame, insert the hex bolt through the handlebar and into the steerer tube.

Use the 5mm end of the Y-wrench to gently tighten the hex bolt into the handlebar so that there's no play between the fork and frame.

Finally, make sure the handlebar, frame, and front wheel are still aligned and tighten the two steering stem screws with the 5mm end of the Y-wrench so the handlebar stays in place.

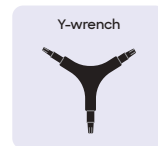

3 Attach the front fender

Attach the front fender to the fork by using the screws that are already in the fork legs.

Use the 4mm end of the Y-wrench to remove the two screws from the fork legs and then tighten the screws through the holes at the end of the fender mounts.

Using the 4mm end of the Y-wrench remove the screw that's on the top of the backside of the fork and tighten the screw through the fender mount bracket on top of the fender so that it's secured tightly to the back of the fork.

When tightening the fender, avoid rubbing the Y-wrench on the frame so the paint doesn't get scratched. Also, don't over tighten the screws to avoid stripping the holes.

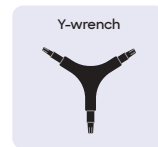
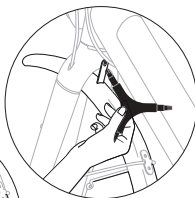
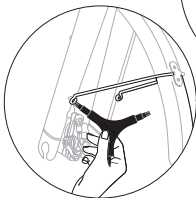

A-FRAME



4 Install the front wheel

Be sure to remove the plastic front rotor protector from the front wheel axle before starting this step.

Align the front wheel axle so that it's inside of the fork slots on both sides. The side with the brake rotor should be aligned so that it fits inside the front disc brake.

Once the fork slots are sitting on both sides of the axle, install washers at both ends and tighten up the cap nuts on the outside using the 15mm end of the wrench.

After installing the front wheel, extend the kickstand for better stability and easier assembly during the next steps.

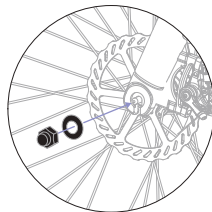

5 Adjust the saddle

Remove the cap that's covering the seat clamp screw, which is located just below the seat.

Insert the seat post into the seat tube. To adjust the height, move it to where it feels comfortable, then tighten the seat clamp screw with the 5mm end of the Y-wrench. Be sure to replace the cap once the seat post is set and tightened.

Warning: do not extend the seat post farther than the minimum insertion line that is indicated on the seat post.

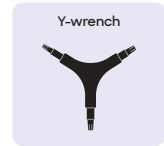

A-FRAME

6 Attach the pedals

Install the left and right pedals by screwing them into the crank.

Pay attention to which pedal is being installed on the left and the right as the left pedal is reverse threaded so it is tightened counter-clockwise. You can tell the two pedals apart by looking for the “R” on the right pedal and “L” on the left.

After the pedals are screwed on by hand, use the 15mm end of the wrench to give the pedals a final tightening.

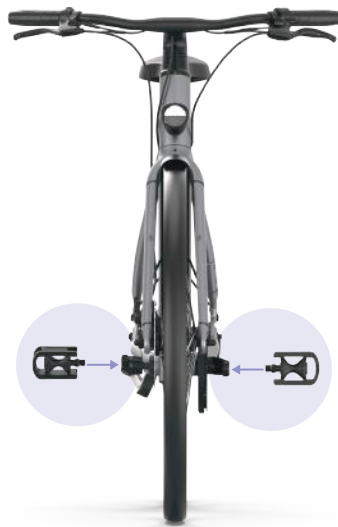
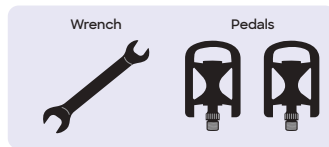
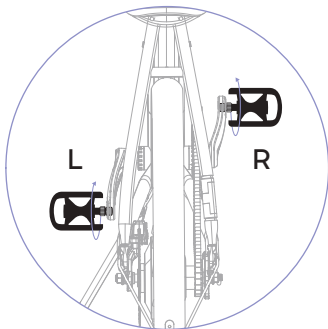

7 Install the display

For the final step before powering on your BirdBike, reinstall the display back into the handlebar so that the Bird logo is at the bottom. Be sure to not pinch the cable inside of the handlebar while reinstalling. Once reinstalled, use the 2.5mm Allen key to replace and tighten the screw under the display so that it's tightened into place inside of the handlebar.

Connect the one end of the power cable coming from the bottom of the display to the other end of the power cable that is coming out of the bottom of the frame. At this point you can power on your BirdBike, but be sure to read through the rest of this manual before riding.

2.5 mm Allen key



BirdBike

V-FRAME



1 Assembly Prep

To prepare for the assembly of your BirdBike, first take out all pieces of the BirdBike from the box and remove all packaging. Also, open the accessory box and remove all tools, parts and everything else that's inside of it.



2.5 mm
Allen key



Pedals
(x 2)



3mm / 4mm /
5mm Y-wrench



L-key Phillips
Screwdriver



13mm / 15mm
Two-sided
Wrench



Cap nut and
washer



Wheel Reflectors
(x 2) and
fasteners (x 2)



Rear and Front
Reflectors



Battery Keys

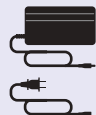

Power Supply
and Cable



This Manual

A-FRAME

Saddle

Rear fender

Rear rim

Tire

Tail light

Rear disc brake

Motor

Kickstand

Front Sprocket

Crank

Pedal

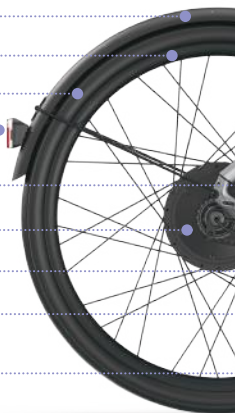

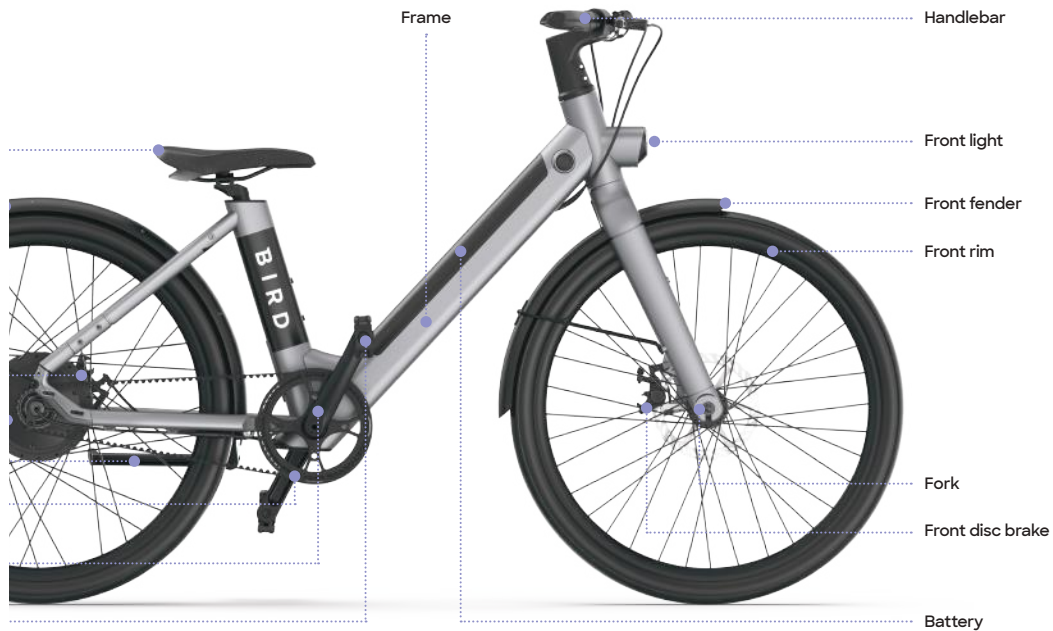

2 Install the handlebar

Remove Display from the Handlebar

Use the 2.5mm Allen Key to remove the screw that's behind the display on the handlebar. If the display isn't easily removed from the handlebar, use the hex key to gently push it from the back of the handlebar through the hole from where the screw was removed.

2.5 mm Allen key



V-FRAME

Install the Handlebar

Use the 5mm end of the Y-wrench to remove the hex bolt from inside the steerer tube and insert the handlebar over the steerer tube.

After the handlebar is installed and lined up properly with the tire and frame, insert the hex bolt through the handlebar and into the steerer tube.

Use the 5mm end of the Y-wrench to gently tighten the hex bolt into the handlebar so that there's no play between the fork and frame.

Finally, make sure the handlebar, frame, and front wheel are still aligned and tighten the two steering stem screws with the 5mm end of the Y-wrench so the handlebar stays in place.

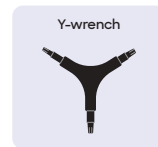

3 Attach the front fender

Attach the front fender to the fork by using the screws that are already in the fork legs.

Use the 4mm end of the Y-wrench to remove the two screws from the fork legs and then tighten the screws through the holes at the end of the fender mounts.

Using the 4mm end of the Y-wrench remove the screw that's on the top of the backside of the fork and tighten the screw through the fender mount bracket on top of the fender so that it's secured tightly to the back of the fork.

When tightening the fender, avoid rubbing the Y-wrench on the frame so the paint doesn't get scratched. Also, don't over tighten the screws to avoid stripping the holes.

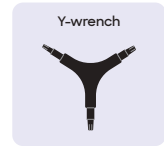

V-FRAME

4 Install the front wheel

Be sure to remove the plastic front rotor protector from the front wheel axle before starting this step.

Align the front wheel axle so that it's inside of the fork slots on both sides. The side with the brake rotor should be aligned so that it fits inside the front disc brake.

Once the fork slots are sitting on both sides of the axle, install washers at both ends and tighten up the cap nuts on the outside using the 15mm end of the wrench.

After installing the front wheel, extend the kickstand for better stability and easier assembly during the next steps.

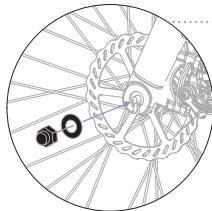

5 Attach the pedals

Install the left and right pedals by screwing them into the crank.

Pay attention to which pedal is being installed on the left and the right as the left pedal is reverse threaded so it is tightened counter-clockwise. You can tell the two pedals apart by looking for the “R” on the right pedal and “L” on the left.

After the pedals are screwed on by hand, use the 15mm end of the wrench to give the pedals a final tightening.

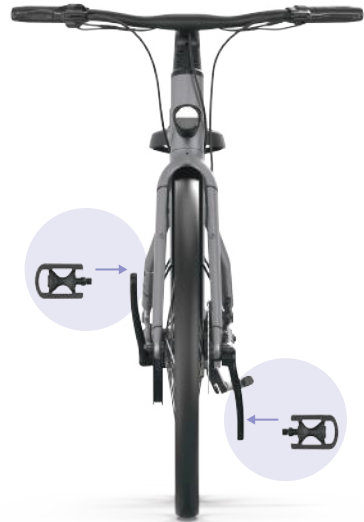
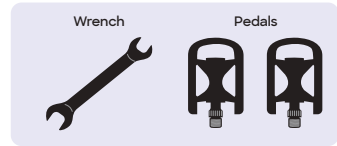
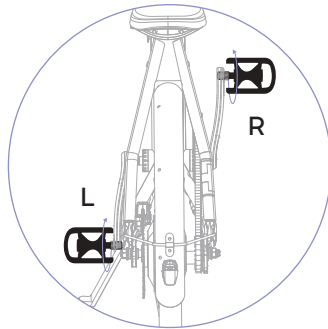

6 Install the display

For the final step before powering on your BirdBike, reinstall the display back into the handlebar so that the Bird logo is at the bottom. Be sure to not pinch the cable inside of the handlebar while reinstalling. Once reinstalled, use the 2.5mm Allen key to replace and tighten the screw under the display so that it's tightened into place inside of the handlebar.

Connect the one end of the power cable coming from the bottom of the display to the other end of the power cable that is coming out of the bottom of the frame. At this point you can power on your BirdBike, but be sure to read through the rest of this manual before riding.



BirdBike

FUNCTIONS OVERVIEW

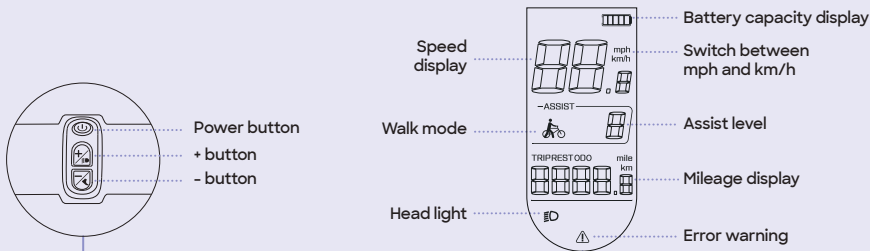

Operating Options



POWER ON/OFF

After long pressing the  **power button**, the BirdBike will be turned on. While the power is on, press and hold the power button again to turn off the power.

The power will automatically shut off after 5 minutes if not being used.



DISPLAY INTERFACE

After the BirdBike is turned on, the display defaults to showing real-time speed and total distance traveled (miles or km). With a short press of the  **power button** you can toggle through the total distance (miles/km) and single trip distance (miles/km).



WALK MODE

After pressing and holding the  **-button** for 2 seconds the BirdBike will go into Walk Mode. The display will show the push symbol and you will receive power-assistance while pushing the BirdBike in more difficult situations, like going uphill. When you release the button, Walk Mode will automatically turn off.

The power-assisted Walk Mode function should only be used while pushing the electric vehicle and never used while riding.





TURN ON/OFF THE HEADLIGHTS

Press and hold the  + **key** for 2 seconds to turn on the headlight. When the headlight is on, the display brightness will also automatically dim. Whenever natural lighting is insufficient (such as in bad weather) or when riding in the dark, you should always turn on the headlight. Press and hold the **+ key** again for 2 seconds to switch off the headlight.



ASSIST LEVEL

Short press the   + / - **buttons** to switch the assist level of the BirdBike and change the output power of the motor. Level 0 is no assistance, and level 5 offers the highest amount of assist. The default level when the BirdBike is first turned on is level 5, and each subsequent time it will default to the last assist level that was used.



BATTERY LEVEL

When the battery is full, the five-segment battery icon will be fully lit and the number of bars will decrease as the battery level decreases. When the battery is low and needs charging, the battery icon will flash.





ERROR CODE DISPLAY



Error code display: For more information on error codes, please visit support.bird.co.

When an error code is displayed, please troubleshoot or contact BirdBike support as soon as possible as the BirdBike will not be able to be ridden normally until the error is resolved.





SETTINGS MODE

To enter **Settings Mode** first power on the BirdBike, then long press and hold   **keys +/-** at the same time. Once in Settings Mode you adjust from mph to km/h, set a speed limit, set wheel diameter, and adjust the brightness of the display.



While In **Settings Mode**, you can toggle up and down with the **up**  (+) and **down**  (-) buttons. Short press the **power button**  to adjust the item you want to change, then short press the power button after making your selection to save.

To exit Settings Mode just long press the **minus button**  for 2 seconds. Also, while in Settings Mode if no operation is performed for 30 seconds, then the display will return back to normal.



■ MPH & KM/H (P1)

When P1 is displayed in the speed position while in Settings Mode, press the   +/- buttons to switch the display between mph or km/h. After selecting, short press the **power button**  to save.

■ SPEED LIMIT (P2)

When P2 is displayed in the speed position while in Settings Mode and the speed limit value is displayed in the trip position, you can then adjust the speed limit with the   +/- buttons. The minimum is 7 mph (12km/h) and the maximum is 20mph (32km/h). After selecting, short press the **power button**  to save.

■ WHEEL DIAMETER (P3)

When P3 is displayed in the speed position while in Settings Mode, the wheel diameter setting will be shown in inches and can be adjusted with the   +/- buttons. Be sure to know the proper sizes as selecting the wrong size can result in unexpected speeds. After selecting, press the  power button so save.



■ DISPLAY BRIGHTNESS (P4)

When P4 is displayed in the speed position while in Settings Mode, the display brightness settings from 1 to 5 are displayed according to the current setting. 1 is the lowest brightness setting, and 5 is the highest (default setting is 5).





After the setting is completed, short press the  power button to save.



■ AUTOMATIC POWER OFF TIMER (P5)

When P5 is displayed at the speed position while in Settings Mode, choose 0-9 by using the   +/- **buttons**, which represents the automatic shutdown time in minutes. The default setting to power off automatically after 5 minutes and setting the timer to 0 means that auto power off will be disabled. After selecting, short press the  **power button** to save.

■ RESET TRIP METER (P6)

When P6 is displayed at the speed position while in Settings Mode, press the   +/- **buttons** to select either Y or N. After selecting Y, short press the  **power button** to reset the trip meter to 0. After resetting the trip meter, short press the power button to save the parameters.

SERVICE REMINDER:

After the BirdBike has been ridden 300 miles (500km), there will be a  service inspection reminder shown on the display the next time it's turned on. If the reminder isn't marked as complete, then it will be displayed every time the vehicle is turned on. The reminder can be cleared by a short press of the  **power button**.

To remove the service reminder completely until the next 300 miles (500km), the rider must connect to the BirdBike through the Bird App and mark the service inspection as complete. Once marked complete in the Bird App, the service reminder will then no longer be displayed by default each time the BirdBike is powered on.

Operation and Safety Instructions

READ BEFORE RIDING 

For your personal safety, you must pay attention to the following safe use of the BirdBike:

- It is recommended to always wear a helmet when riding.
- Do not exceed the maximum load of 265 lbs (120.2 kg) and no more than one rider at a time.
- When riding in rain or snow, it will take longer to slow the vehicle, so be aware of braking earlier than normal.
- Try to avoid riding in severe weather, such as heavy rain, snow, or wind.

For your personal safety, you must pay attention to the following safe use of electric bicycles:

- Do not park the BirdBike in building halls, evacuation stairs, or walkways.
- Do not charge or park the BirdBike in residential buildings.

Keep away from combustibles when charging, and do not leave charging for an extended period of time.

The battery should be used and maintained correctly in accordance with the method required by this manual. The battery should not be disassembled without authorization and should be recycled by professional experts.

- The charger should be used and maintained correctly in accordance with the method required by this manual.
- Carefully read the warning labels and instructions of the charger before use. When replacing the charger, it should be purchased from Bird only.
- Before washing the ebike, you should read and understand the part of the manual about the "Precautions for washing".
- When adjusting the handlebars or saddles, care should be taken not to expose the safety marks of the handlebars and saddles.
- Always check your BirdBike before riding. If there are any issues found, please seek professional assistance with solving the issue or repair.
- Always check whether the front and rear brakes work normally.
- Always check that handlebars, front and rear wheels, and all other parts of the BirdBike are tightened properly.

Precautions while riding:

- Pay attention and observe all pedestrians, vehicles, obstacles, and others using the road at all times.

- Do not drive under the influence of alcohol.
- Anyone who suffers from diseases such as hypertension, hernia, concussion, epilepsy, and cardiovascular disease should not ride the BirdBike.
- Do not follow motor vehicles too closely (because they may slow down or turn at any time), and always pay attention to the brakes.
- Do not touch things on the road with your feet while riding.
- While riding at high speed, be sure to brake the bike slowly, and do not brake suddenly under any circumstances.
- When driving at night, slow down, drive with caution and use the lights of the vehicle.
- Try to ride in designated bicycle lanes or the edge of the road, in the direction of traffic flow.
- Stop at stop signs, slow down and watch traffic at intersections.
- Jackets, boots, trousers, gloves, etc. are effective protective clothing to prevent abrasions if an accident were to occur while riding. It is recommended to wear them to protect yourself.
- Do not wear loose clothing to avoid the risk of entanglement in the moving parts of the BirdBike.
- Please wear appropriate safety equipment according to the type of riding you plan to do. It is best to wear a pair of sports

sunglasses, which can reduce the damage of ultraviolet rays to the eyes and protect the eyes from tree branches and flying rocks or stones.

- Please perform regular maintenance and inspection of your BirdBike.
- Please do not replace any parts by yourself to avoid damage.
- If any parts are damaged while riding that affect safety, please stop riding immediately.
- You should not listen to music while riding (because when you listen, it distracts your attention, and you cannot hear the sound of horns or other sounds of motor vehicles, which is very dangerous)
- If you have any problems while riding, please resolve the problem if possible or contact Bird support for help.

Precautions for washing the BirdBike:

- When washing the BirdBike, do not directly pour water on the motor and the front and rear axles to prevent water from affecting the performance and life of the product. When washing the BirdBike, do not use a strong steam or high-pressure water spray.
- After washing the vehicle or riding through water, pay special attention to the working conditions of the brakes. The braking capability may be reduced in these circumstances.

Maintenance and general troubleshooting

Inspection of handlebar and front & rear wheel:

- Move the BirdBike up, down, front, back, left and right to check whether the handlebars and the axle nuts of the front and rear wheels are tightened properly, whether the handlebars are tightened properly, and whether there is any abnormal rubbing or damage happening between parts
- Push the vehicle back and forth to check whether the front and rear wheels rotate smoothly and without any abnormal noise or rubbing.
- Carefully check the entire vehicle before riding and if you find any issues, please contact a professional for repair or contact Bird support for help.

Inspection of power circuit and lighting circuit

- Turn on the power, operate the lighting switch, check whether the headlights and taillights are on, and if they are at normal levels.
- Check for any damage with the lighting system.
- Check whether the power cables on the BirdBike are connected and are operating safely as intended as well as whether all connectors are functioning properly.

Inspection of front and rear brakes

- Adjustment of the brake lever: Pinch the front and rear brake levers, and confirm whether the brakes are working when the distance between the brake lever and the handlebar is ½ inch.
- Adjustment method of the front and rear brakes: The distance between the brake and the brake lever is specified to be between 10-20mm.
- When the brake is in a tightly gripped state, the brake pad and the brake disc should be contacting evenly.
- The brake pads and brake discs should be replaced at the same time (the adjustment of the rear wheel brake is the same as that of the front wheel brake).

Battery installation status

- Confirm that the battery is in a fixed state, connected, and operating properly.

Saddle adjustment

- The proper height of the saddle is to sit on the saddle with the toes of both feet just touching the ground.

Damage or contamination of reflectors

- Check whether the reflectors are dirty or damaged. If they are then clean or replace them.

The fixed state of wheel axles

- Please confirm that the front and rear axles of the wheels are not shaking or loose.

Inflation, wear, and damage of tires

- Please confirm whether the tire inflation is appropriate. Improper inflation can cause punctures and loosening of various parts of the BirdBike. In addition, please determine whether there is a high amount of wear or any foreign objects or nails in either of the tires. If so, do not ride before fixing the issue or repairing the tire(s).

Adjustment of pedals and other moving parts

- The pedals should rotate smoothly. If either is loose, please tighten it.

Charge and discharge port

- Please make sure that the charging and discharging ports are not damaged.
- Also make sure that no foreign objects have entered into the ports, that the ports are not deformed, and that the port covers are not damaged.

BirdBike Limited Manufacturer's Warranty

The BirdBike comes with a limited manufacturer's warranty and is covered from any defects or issues that are outside of normal wear & tear within the warranty period and terms outlined at support.bird.co.

Do not modify the BirdBike as it will void your warranty and introduce potential safety issues. Read and understand all safety warnings listed on the product label and in this manual.

Proof of purchase must be verified before any warranty claim is filed.

Warranty terms only apply to the original owner.

If you need any type of support or warranty information for your BirdBike, please contact us before returning it back to wherever you purchased it. The BirdBike Support Team is ready to help you via phone or email and you can also visit support.bird.co for more info.

Phone: 1-888-309-3702 (M-F 9a-5p EST)

Email: BirdBike@bird.co

Web: support.bird.co

Federal Communications Commission (FCC) Compliance Statement for USA

This device complies with part 15 of the FCC rules. Operation is subject to the following two conditions: (1) This device may not cause harmful interference, and (2) this device must accept any interference received, including interference that may cause undesired operation.

Note: This equipment has been tested and found to comply with the limits for a Class B digital device, pursuant to part 15 of the FCC Rules. These limits are designed to provide reasonable protection against harmful interference in a residential installation. This equipment generates, uses, and can radiate radio frequency energy; if not installed and used in accordance with the instructions, it may cause harmful interference to radio communications. There is no guarantee that interference will not occur in a particular installation. If this equipment does cause harmful interference to radio or television reception, which can be determined by powering the equipment off and on, the user is encouraged to try to correct the interference by using any of the following measures:

- Reorienting or relocating the receiving antenna.
- Increasing the separation between the equipment and receiver.

- Connecting the equipment into an outlet on a circuit different from that to which the receiver is connected. Consult the dealer or an experienced radio/TV technician for help.

This equipment complies with FCC radiation exposure limits set forth for an uncontrolled environment.

Prop 65 Warning

This product can expose you to chemicals including chromium, which is known to the State of California to cause cancer and birth defects or other reproductive harm.

For more information go to: <http://www.p65warnings.ca.gov>.



Questions? We've got answers.

Visit support.bird.co for more info.

Phone: 1-888-309-3702 (M-F 9a-5p EST)

Email: BirdBike@bird.co